



ON Semiconductor®

<http://onsemi.com>

# STK5F4U3E2D-E

## Advance Information

Thick-Film Hybrid IC

## Inverter Power H-IC for 3-phase Motor Drive

### Overview

This "Inverter Power H-IC" is highly integrated device containing all High Voltage (HV) control from HV-DC to 3-phase outputs in a single DIP module (Dual-In line Package). Output stage uses IGBT/FRD technology and implements Under Voltage Protection (UVP) and Over Current Protection (OCP) with a Fault Detection output flag. Internal Boost diodes are provided for high side gate boost drive.

### Function

- Single control power supply due to Internal bootstrap circuit for high side pre-driver circuit
- All control inputs and status outputs are at low voltage levels directly compatible with microcontrollers.
- A single power supply drive is enabled through the use of bootstrap circuits for upper power supplies
- Built-in dead-time for shoot-thru protection
- Having open emitter output for low side IGBTs; individual shunt resistor per phase for OCP
- Externally accessible embedded thermistor for substrate temperature measurement
- Shutdown function 'ITRIP' to disable all operations of the 6 phase output stage by external input

### Certification

- UL1557 (File number: E339285).

### Specifications

**Absolute Maximum Ratings** at Ta = 25°C

Parameter	Symbol	Remarks	Ratings	Unit
Supply voltage	VCC	P to NU,NV,NW, surge < 500V *1	450	V
Collector-emitter voltage	VCE	P to U,V,W, U to NU, V toNV, or W to NW	600	V
Output current	Io	P, N, U,V,W terminal current.	±50	A
		P, N, U,V,W terminal current. Tc=100°C	±25	
Output peak current	Iop	P, N, U,V,W terminal current, PW=1ms.	±100	A
Pre-driver supply voltage	VD1,2,3,4	VB1-VS1,VB2-VS2,VB3-VS3,VDD-VSS *2	20	V
Input signal voltage	VIN	HIN1, 2, 3, LIN1, 2, 3, terminal.	-0.3 to VDD	V
FAULT terminal voltage	VFAULT	FAULT terminal.	-0.3 to VDD	V
Maximum loss	Pd	IGBT per channel	62.5	W
Junction temperature	Tj	IGBT, FRD	150	°C
Storage temperature	Tstg		-40 to +125	°C
Operating temperature	Tc	HIC case	-20 to +100	°C
Tightening torque	MT	A screw part at use M4 type screw *3	1.17	Nm
Withstand Voltage	Vis	50Hz sine wave AC 1 minute *4	2000	VRMS

Reference voltage is "VSS" terminal voltage unless otherwise specified.

\*1: Surge voltage developed by the switching operation due to the wiring inductance between the P and N terminals.

\*2: Terminal voltage: VD1=VB1-VS1, VD2=VB2-VS2, VD3=VB3-VS3, VD4=VDD-VSS.

\*3: Flatness of the heat-sink should be 0.25mm and below.

\*4. Test conditions: AC 2500V, 1 second.

Stresses exceeding Maximum Ratings may damage the device. Maximum Ratings are stress ratings only. Functional operation above the Recommended Operating Conditions is not implied. Extended exposure to stresses above the Recommended Operating Conditions may affect device reliability.

This document contains information on a new product. Specifications and information herein are subject to change without notice.

### ORDERING INFORMATION

See detailed ordering and shipping information on page 14 of this data sheet.

# STK5F4U3E2D-E

## Electrical Characteristics at Tc= 25°C, VD1, VD2, VD3, VD4=15V

Parameters	Symbols	Conditions	Test Circuit	Ratings			Unit
				Min.	Typ.	Max.	
<b>Power output section</b>							
Collector-to-emitter cut-off current	ICE	VCE=600V	Fig.1	-	-	1.0	mA
Boot-strap diode reverse current	IR(BD)	VR(BD)=600V	-	-	-	0.5	mA
Collector-to-emitter saturation voltage	VCE(sat)	Io=50A, Tj=25°C	Fig.2	-	1.7	2.6	V
		Io=25A, Tj=100°C		-	2.3	-	
Diode forward voltage	VF	Io=50A, Tj=25°C	Fig.3	-	1.8	2.7	V
		Io=25A, Tj=100°C		-	2.5	-	
Junction to case thermal resistance	θj-c(T)	IGBT	-	-	1.5	-	°C/W
	θj-c(D)	FWD	-	-	1.8	-	°C/W
<b>Control (Pre-driver) section</b>							
Pre-drive power supply consumption current	ID	VD1,2,3=15V	Fig.4	-	0.05	0.4	mA
		VD4=15V		-	1.0	4.0	
High level input voltage	Vin H	HIN1,HIN2,HIN3,	-	2.5	-	-	V
Low level input voltage	Vin L	LIN1,LIN2,LIN3	-	-	-	0.8	V
<b>Protection section</b>							
ITRIP threshold voltage	VITRIP	ITRIP(17) to VSS(19)	Fig.5	0.44	0.49	0.54	V
Pre-drive low voltage protection	UVLO		-	10	-	12	V
FAULT terminal input electric current	IOSD	VFAULT=0.1V	-	-	1.5	-	mA
FAULT clearance delay time	FLTCLR	From time fault condition clear	-	1.0	-	3.0	ms
Thermistor for substrate temperature monitor	Rt	Resistance between the TH1 and TH2 terminals	-	90	-	110	kΩ
<b>Switching character</b>							
Switching time	tON	Io=50A, Inductive load	Fig.6	-	0.7	1.5	μs
	tOFF			-	1.1	2.1	μs
Turn-on switching loss	Eon	Io=50A, VCC=300V, VD=15V, L=280μH		-	1100	-	μJ
Turn-off switching loss	Eoff			-	1200	-	μJ
Total switching loss	Etot			-	2300	-	μJ
Turn-on switching loss	Eon	Io=50A, VCC=300V, VD=15V, L=280μH, Tc=100°C		-	1200	-	μJ
Turn-off switching loss	Eoff			-	1350	-	μJ
Total switching loss	Etot			-	2550	-	μJ
Diode reverse recovery energy	Erec	Io=50A, VCC=300V, VD=15V, L=280μH,		-	52.5	-	μJ
Diode reverse recovery time	Trr	Tc=100°C		-	104	-	ns

Reference Voltage is "VSS" terminal voltage unless otherwise specified.

## STK5F4U3E2D-E

### Notes

- When the internal protection circuit operates, a FAULT signal is turned ON (When the FAULT terminal is low level, FAULT signal is ON state : output form is open DRAIN) but the FAULT signal does not latch. After protection operation ends, it returns automatically within about 1ms to 3ms and resumes operation beginning condition. So, after FAULT signal detection, set all input signal to OFF (Low) at once. However, the operation of pre-drive power supply low voltage protection (UVLO:with hysteresis about 0.2V) is as follows.

#### Upper side:

The gate is turned off and will return to regular operation when recovering to the normal voltage, but the latch will continue till the input signal will turn 'low'

#### Lower side:

The gate is turned off and will automatically reset when recovering to normal voltage. It does not depend on input signal voltage.

- When assembling the H-IC on the heat sink with M4 type screw, tightening torque range is 0.79Nm to 1.17Nm.
- The pre-drive low voltage protection is the feature to protect a device when the pre-driver supply voltage falls due to an operating malfunction.
- When use the over-current protection with external resistors, please set the current protection level to be equal or less than the rating of output peak current (I<sub>op</sub>).

### Pin Assignment

Pin No.	Name	Description	Pin No.	Name	Description
1	VB1	High side floating supply voltage 1	44	P	Positive bus input voltage
2	VS1	High side floating supply offset voltage	43	P	Positive bus input voltage
3	-	Without pin	42	P	Positive bus input voltage
4	VB2	High side floating supply voltage 2	41	-	Without pin
5	VS2	High side floating supply offset voltage	40	U	U+ phase output
6	-	Without pin	39	U	U+ phase output
7	VB3	High side floating supply voltage 3	38	U	U+ phase output
8	VS3	High side floating supply offset voltage	37	-	Without pin
9	-	Without pin	36	V	V+ phase output
10	HIN1	Logic input high side driver-Phase1	35	V	V+ phase output
11	HIN2	Logic input high side driver-Phase2	34	V	V+ phase output
12	HIN3	Logic input high side driver-Phase3	33	-	Without pin
13	LIN1	Logic input low side driver-Phase1	32	W	W+ phase output
14	LIN2	Logic input low side driver-Phase2	31	W	W+ phase output
15	LIN3	Logic input low side driver-Phase3	30	W	W+ phase output
16	FAULT	Fault out	29	-	Without pin
17	ITRIP	Over-current protection level setting pin	28	NU	U- phase output
18	VDD	+15V main supply	27	NU	U- phase output
19	VSS1	Negative main supply	26	NV	V- phase output
20	VSS2	Negative main supply	25	NV	V- phase output
21	TH1	Thermistor out	24	NW	W- phase output
22	TH2	Thermistor out	23	NW	W- phase output

Block Diagram

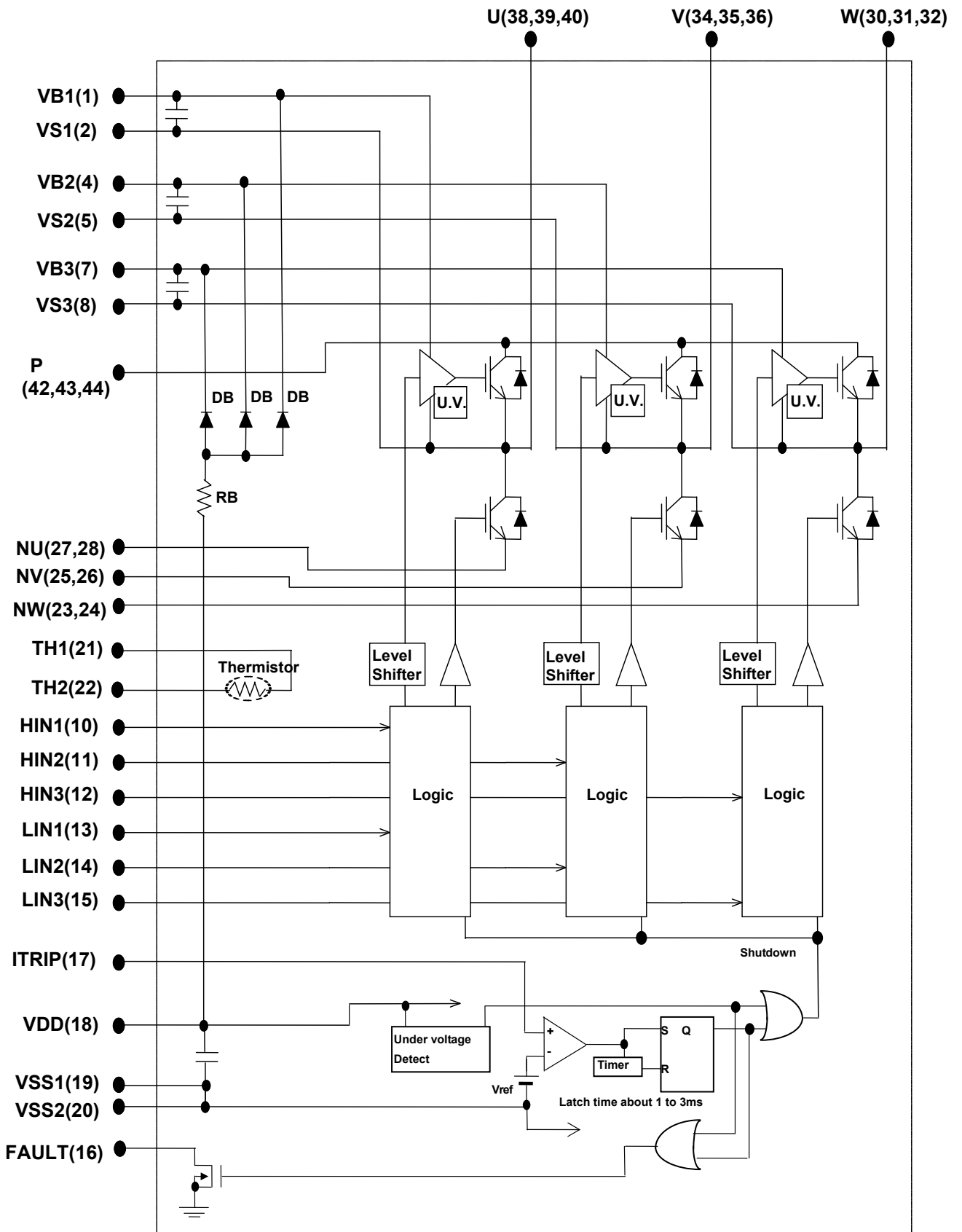

## Test Circuit

(The tested phase: U+ shows the upper side of the U phase and U- shows the lower side of the U phase.)

### ■ ICE / IR(BD)

	U+	V+	W+	U-	V-	W-
M	42	42	42	38	34	30
N	38	34	30	27	25	23

	U(BD)	V(BD)	W(BD)
M	1	4	7
N	19	19	19

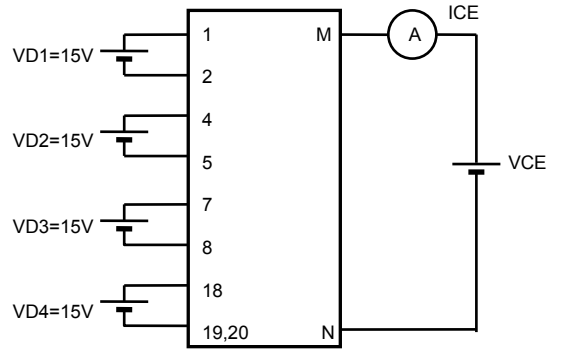

Fig.1

### ■ VCE(SAT) (Test by pulse)

	U+	V+	W+	U-	V-	W-
M	42	42	42	38	34	30
N	38	34	30	27	25	23
m	10	11	12	13	14	15

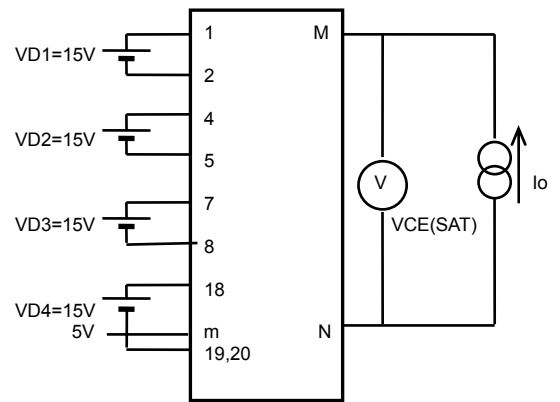

Fig.2

### ■ VF (Test by pulse)

	U+	V+	W+	U-	V-	W-
M	42	42	42	38	34	30
N	38	34	30	27	25	23

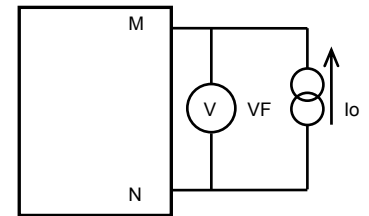

Fig.3

### ■ ID

	VD1	VD2	VD3	VD4
M	1	4	7	18
N	2	5	8	19

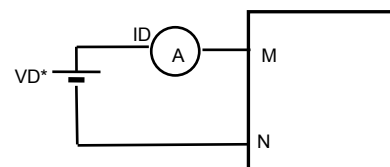

Fig.4

# STK5F4U3E2D-E

## ■ ISD (The circuit is a representative example of the lower side U phase.)

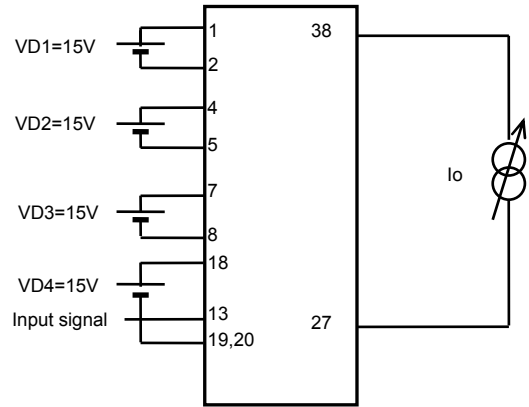
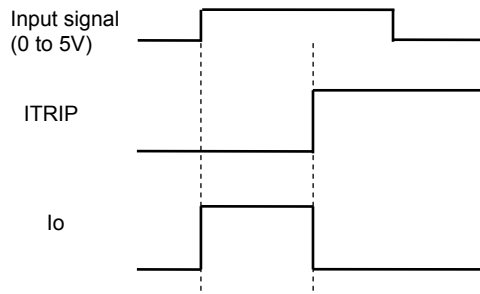

Fig.5

## ■ Switching time (The circuit is a representative example of the lower side U phase.)

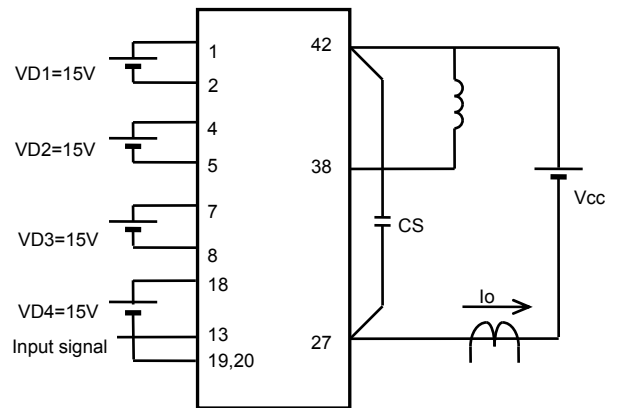
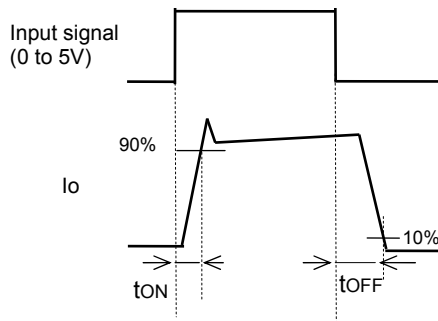

Fig.6

## ■ RB-SOA (The circuit is a representative example of the lower side U phase.)

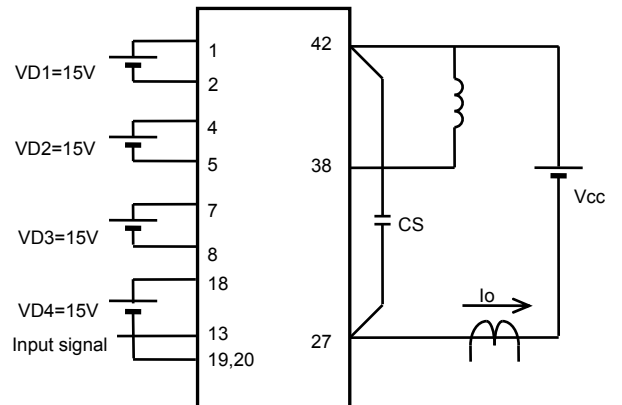
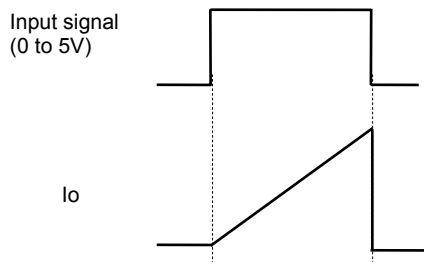
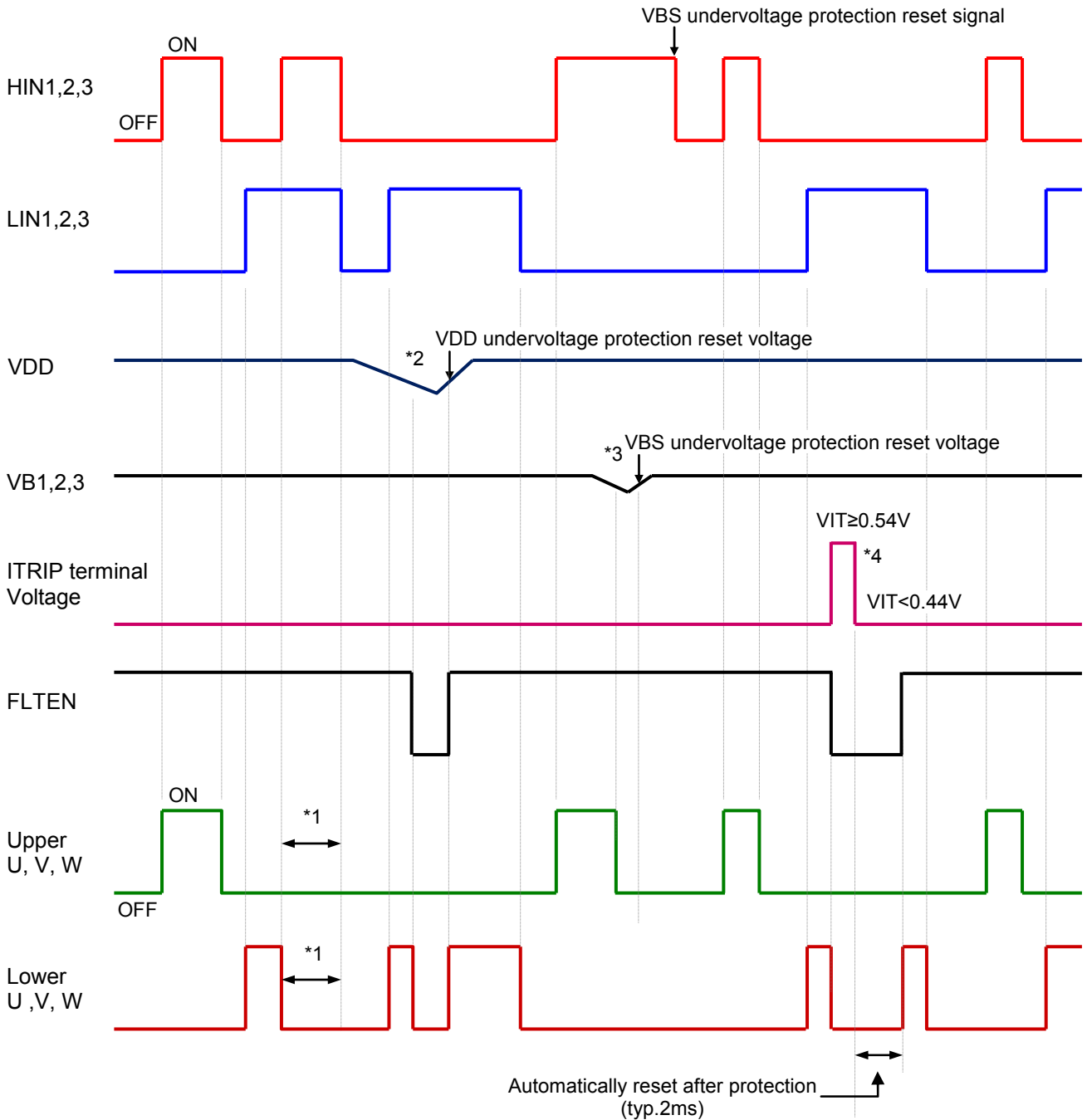

Fig.7

Input / Output Timing Chart



Notes:

- \*1 : Diagram shows the prevention of shoot-thru via control logic, however, more dead time must be added to account for switching delay externally.
- \*2 : When VDD decreases all gate output signals will go low and cut off all 6 IGBT outputs. When VDD rises the operation will resume immediately.
- \*3 : When the upper side voltage at VB1, VB2 and VB3 drops only the corresponding upper side output is turned off. The outputs return to normal operation immediately after the upper side gate voltage rises.
- \*4 : When VITRIP exceeds threshold all IGBT's are turned off and normal operation resumes 2ms (typ) after over current condition is removed.

Logic level table

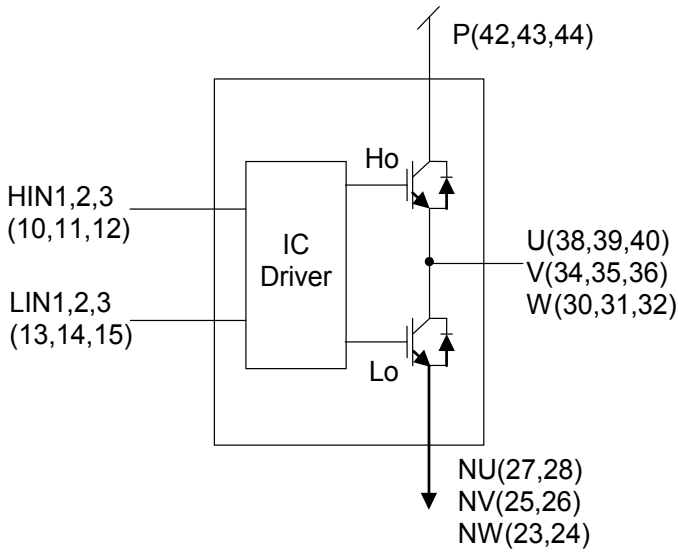

FLTEN	Itrip	HIN1,2,3	LIN1,2,3	U,V,W
1	0	1	0	Vbus
1	0	0	1	0
1	0	0	0	Off
1	0	1	1	Off
1	1	X	X	Off
0	X	X	X	Off

Application Circuit Example

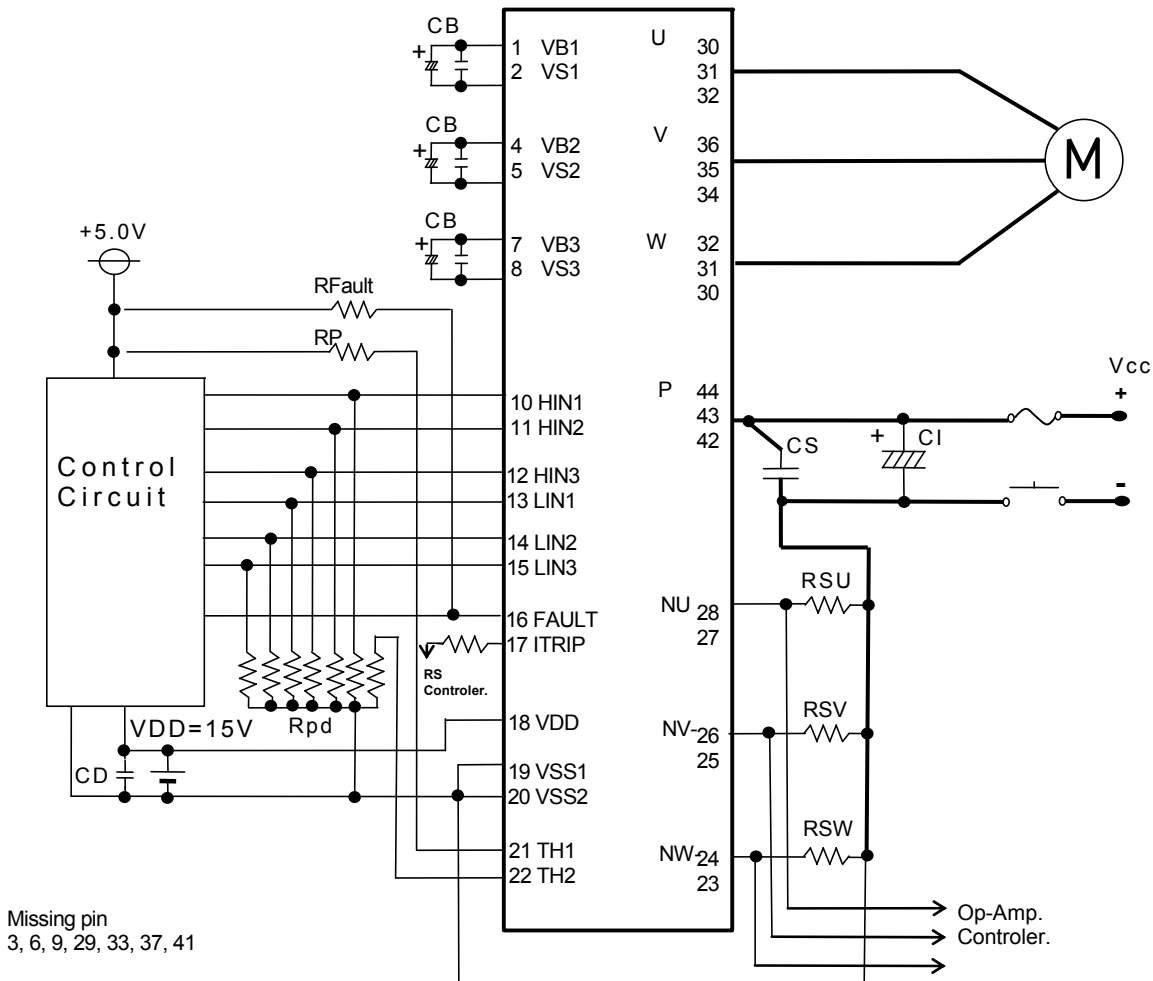

Missing pin  
3, 6, 9, 29, 33, 37, 41



## Recommended Operating Conditions at Tc = 25°C

Parameter	Symbol	Conditions	Ratings			Unit
			min	typ	max	
Supply voltage	VCC	P to NU,NV,NW	0	280	400	V
Pre-driver supply voltage	VD1,2,3	VB1 –VS1,VB2 –VS2,VB3 –VS3	12.5	15	17.5	V
	VD4	VDD – VSS *1	13.5	15	16.5	
Input ON voltage	VIN(ON)	HIN1,HIN2,HIN3, LIN1,LIN2,LIN3	3.0	-	5.0	V
Input OFF voltage	VIN(OFF)		0	-	0.3	
PWM frequency	fPWM		1.0	-	20	kHz
Dead time	DT	Upper/lower input signal downtime	2	-	-	µs
Allowable input pulse width	PWIN	ON pulse width/OFF pulse width	1	-	-	
Tightening torque	MT	'M4'Type Screw	0.79	-	1.17	Nm

\*1 Pre-driver power supply (VD4=15±1.5V) must have the capacity of Io=20mA(DC), 0.5A(Peak).

## Usage Precautions

1. This H-IC includes internal bootstrap diodes and resistors. By adding a bootstrap capacitor "CB", a high side drive voltage is generated; each phase requires an individual bootstrap capacitor. The recommended value of CB is in the range of 1 to 47µF (±20%), however this value needs to be verified prior to production. If selecting the capacitance more than 47µF (±20%), connect a resistor (about 40Ω) in series between each 3-phase upper side power supply terminals (VB1,2,3) and each bootstrap capacitor. When not using the bootstrap circuit, each upper side pre-drive power supply requires an external independent power supply.
2. It is essential that wiring length between terminals in the snubber circuit be kept as short as possible to reduce the effect of surge voltages. Recommended value of "CS" is in the range of 0.1 to 10µF.
3. "FAULT" (16pin) is open DRAIN output terminal (Active Low). Pull up resistor is recommended more than 5.6kΩ.
4. Inside the H-IC, a thermistor used as the temperature monitor for internal substrate is connected between "TH1" and "TH2". Generally, one of terminals is connected to VSS, and the other is pulled up to external power supply with pull-up resistor (Rp) externally. The temperature monitor example application is as follows please refer the Fig.11 and Fig.12 below.
5. The pull-down resistor 33kΩ is provided internally at the signal input terminals. An external resistor of 2.2kΩ to 3.3kΩ should be added to reduce the influence of external wiring noise.
6. As protection of H-IC to unusual current by a short circuit etc, it recommended installing shunt resistors and an over-current protection circuit outside. Moreover, for safety, a fuse on Vcc line is recommended.
7. Disconnection of terminals U, V, W, during normal motor operation will cause damage to H-IC, use caution with this connections.
8. The "ITRIP" terminal (17pin) is the input terminal to shut down. When VITRIP exceeds threshold (0.44V to 0.54V), all IGBTs are turned off. And normal operation resumes 2ms(typ) after over current condition is removed. Therefore, please turn all the input signal off (Low) in case of detecting error at the "FAULT" terminal.
9. When input pulse width is less than 1µs, an output may not react to the pulse. (Both ON signal and OFF signal)

The characteristic of thermistor

Parameter	Symbol	Condition	Min	Typ.	Max	Unit
Resistance	$R_{25}$	$T_c=25^{\circ}\text{C}$	97	100	103	$\text{k}\Omega$
Resistance	$R_{100}$	$T_c=100^{\circ}\text{C}$	4.93	5.38	5.88	$\text{k}\Omega$
B-Constant(25-50°C)	B		4165	4250	4335	K
Temperature Range			-40		+125	$^{\circ}\text{C}$

This data shows the example of the application circuit, does not guarantee a design as the mass production set.

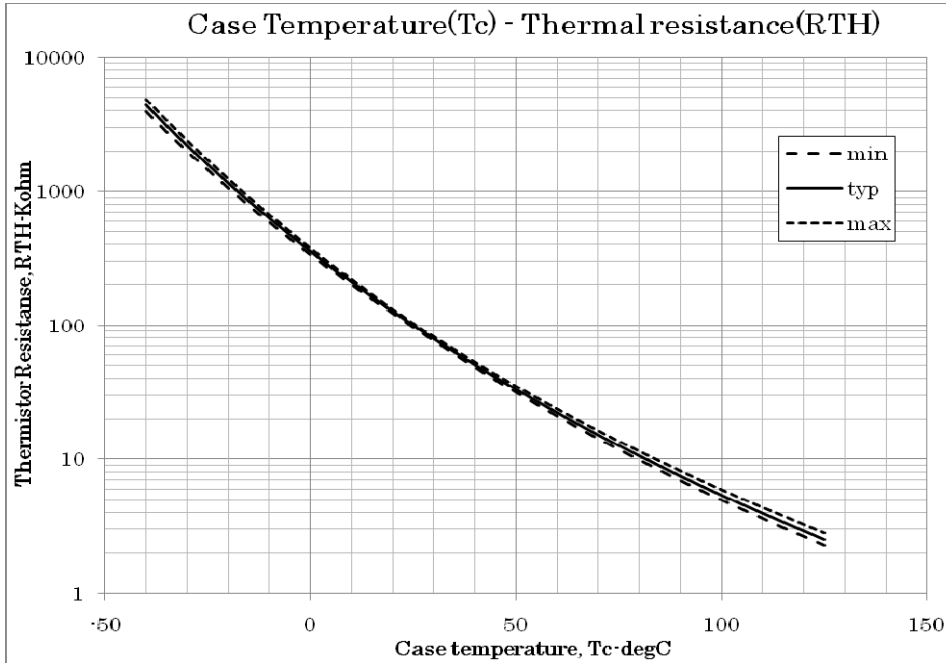

Fig.11 Variation of thermistor resistance with temperature

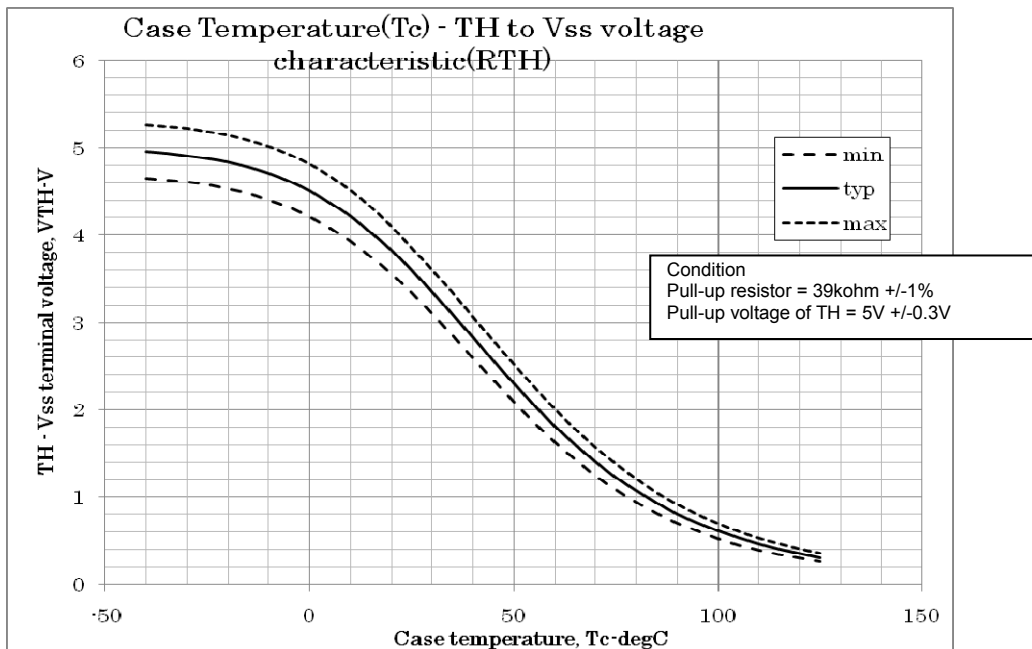

Fig.12 Variation of temperature sense voltage with thermistor temperature

# STK5F4U3E2D-E

## Io-f curve

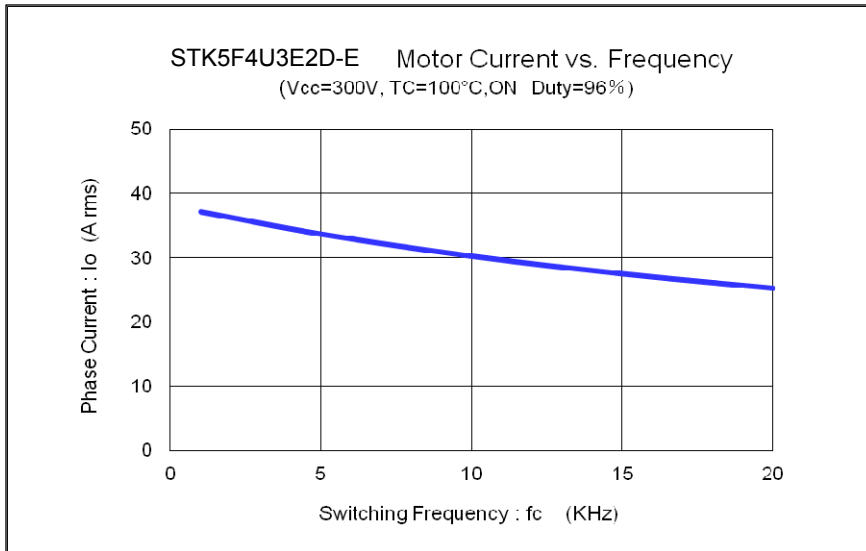

Fig.13 Maximum sinusoidal phase current as function of switching frequency at Tc=100°C, Vcc=300V

## Switching waveform

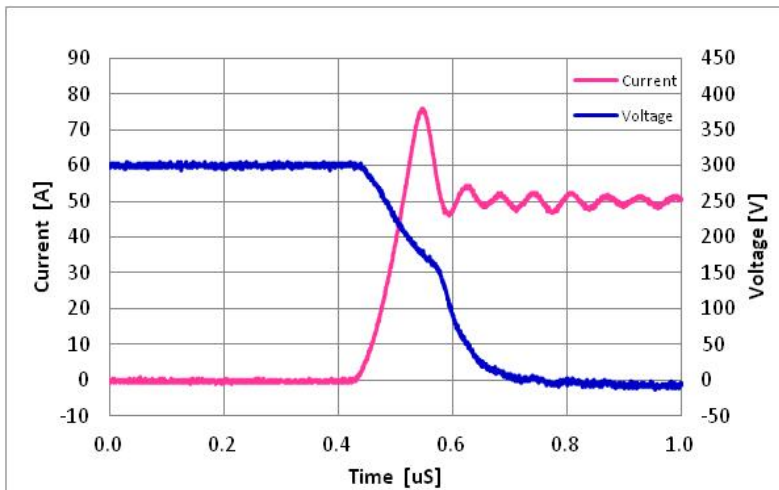

Fig. 14 IGBT Turn-on. Typical turn-on waveform at Tc=100°C, Vcc=300V, Ic=50A

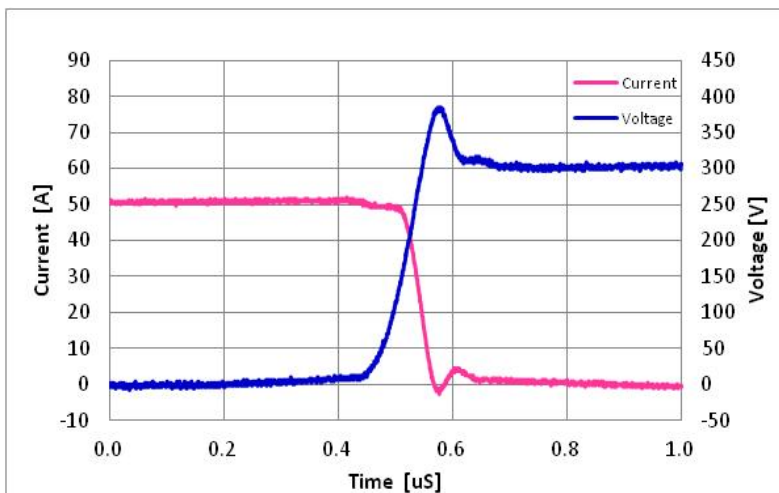

Fig. 15 IGBT Turn-off. Typical turn-off waveform Tc=100°C, Vcc=300V, Ic=50A

Capacitor value calculation for Boot strap (Cb)

Calculate condition

Item	Symbol	Value	Unit
Upper side power supply	VBS	15	V
Total gate charge of output power IGBT at 15V.	Qg	0.9	μC
Upper side power supply low voltage protection.	UVLO	12.5	V
Upper side power dissipation.	IDMAX	120	μA
ON time required for CB voltage to fall from 15V to UVLO	TONMAX	-	s

Capacitance calculation formula

TONMAX is upper arm maximum on time equal the time when the CB voltage falls from 15V to the upper limit of Low voltage protection level.

"ton-maximum" of upper side is the time that CB decreases 15V to the maximum low voltage protection of the upper side (12V). Thus, CB is calculated by the following formula.

$$VD \times CB - Qg - IDMAX \times TONMAX = UVLO \times CB$$

$$CB = (Qg + IDMAX \times TONMAX) / (VD - UVLO)$$

The relationship between TONMAX and CB becomes as follows. CB is recommended to be approximately 3 times the value calculated above. The recommended value of CB is in the range of 1 to 47μF, however, the value needs to be verified prior to production.

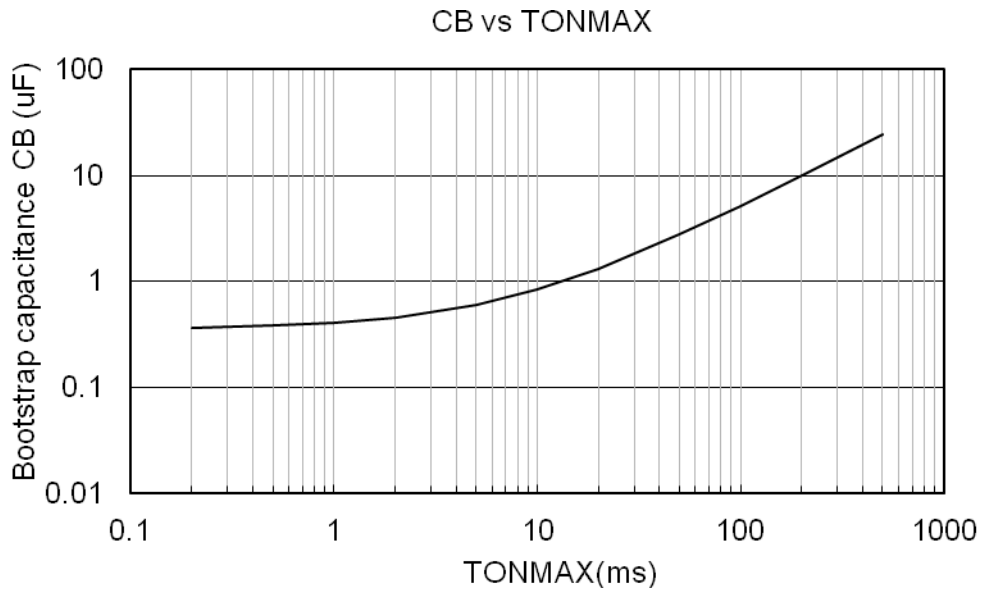

Fig.16 TONMAX vs CB characteristic

# STK5F4U3E2D-E

## Package Dimensions

unit : mm

Missing Pin : 3,6,9,29,33,37,41

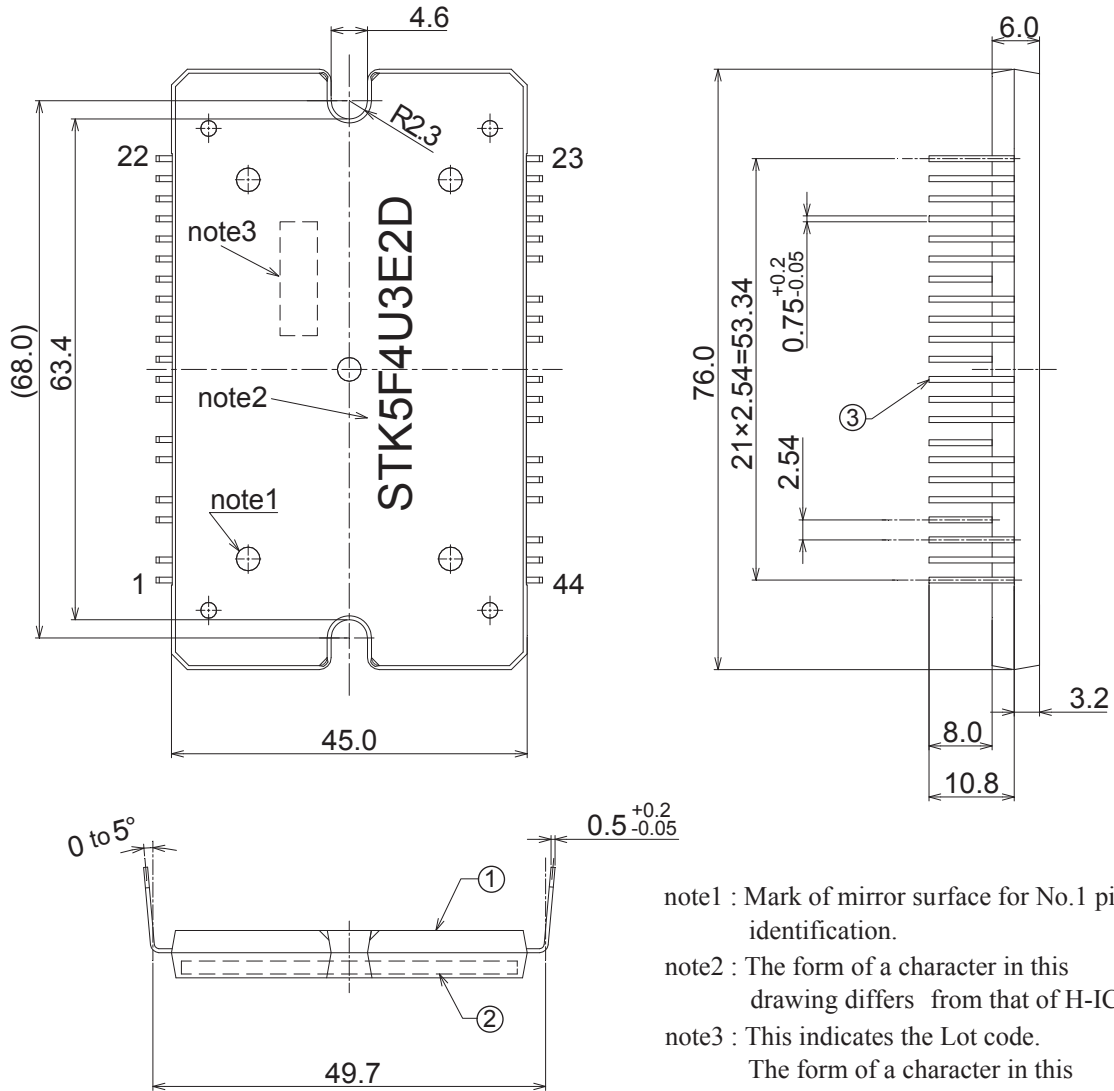

- note1 : Mark of mirror surface for No.1 pin identification.
- note2 : The form of a character in this drawing differs from that of H-IC.
- note3 : This indicates the Lot code.  
The form of a character in this drawing differs from that of H-IC.

Part Name	Material	Treatment
① : Case	EPOXY	-
② : Substrate	IMST Substrate	-
③ : Lead Frame	Cu	Sn

# STK5F4U3E2D-E

---

## ORDERING INFORMATION

Device	Package	Shipping (Qty / Packing)
STK5F4U3E2D-E	610AC-DIP4-UL (Pb-Free)	6 / Fan-Fold

ON Semiconductor and the ON logo are registered trademarks of Semiconductor Components Industries, LLC (SCILLC). SCILLC owns the rights to a number of patents, trademarks, copyrights, trade secrets, and other intellectual property. A listing of SCILLC's product/patent coverage may be accessed at [www.onsemi.com/site/pdf/Patent-Marking.pdf](http://www.onsemi.com/site/pdf/Patent-Marking.pdf). SCILLC reserves the right to make changes without further notice to any products herein. SCILLC makes no warranty, representation or guarantee regarding the suitability of its products for any particular purpose, nor does SCILLC assume any liability arising out of the application or use of any product or circuit, and specifically disclaims any and all liability, including without limitation special, consequential or incidental damages. "Typical" parameters which may be provided in SCILLC data sheets and/or specifications can and do vary in different applications and actual performance may vary over time. All operating parameters, including "Typicals" must be validated for each customer application by customer's technical experts. SCILLC does not convey any license under its patent rights nor the rights of others. SCILLC products are not designed, intended, or authorized for use as components in systems intended for surgical implant into the body, or other applications intended to support or sustain life, or for any other application in which the failure of the SCILLC product could create a situation where personal injury or death may occur. Should Buyer purchase or use SCILLC products for any such unintended or unauthorized application, Buyer shall indemnify and hold SCILLC and its officers, employees, subsidiaries, affiliates, and distributors harmless against all claims, costs, damages, and expenses, and reasonable attorney fees arising out of, directly or indirectly, any claim of personal injury or death associated with such unintended or unauthorized use, even if such claim alleges that SCILLC was negligent regarding the design or manufacture of the part. SCILLC is an Equal Opportunity/Affirmative Action Employer. This literature is subject to all applicable copyright laws and is not for resale in any manner.